

Specification

Model		METG-8		
Positioning repeatability (mm)		±0.005		
Ball screw lead (mm)		5	10	20
Max. speed (*1) (mm/s)		250	500	1000
AC servo motor (W)		200W, 400W		
Max. payload	Horizontal (kg)	50	30	18
	Vertical (kg)	15	8	3
Rated thrust (*2) (N)		683 (1388)	341 (694)	174 (347)
Stroke (*3) (mm)		50~1100 / 50 pitch		
Ball screw (mm)		C7ø16		
Coupling (mm)		10×14/11 (*4)		
Slot-type photomicro sensor		EE-SX674 (NPN)		

*1. Acceleration and deceleration values are set to 0.2 second.

*2. () Value for 400W motor.

*3. Reduce the speed when the stroke exceeds 750 mm due to resonance.

*4. Motor 200W shaft diameter: Panasonic: 11mm, Other: 14 mm.

Sensor layout

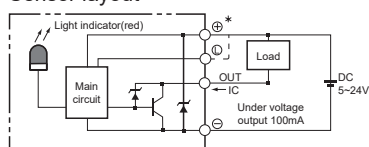

Order example

METG – 8 – L10 – 100 – BC – M20 – C4

Model

Size

Stroke

50~1100 mm
50 mm pitch

Ball screw lead	
L05	5 mm
L10	10 mm
L20	20 mm

Motor position	
BC	Direct connection
BM	Lower side
BR	Right side
BL	Left side

Flange (For motor installation)			
Applicable motor brand (*1)		Power output	
M	Mitsubishi	20	200W 400W servo
	Yaskawa		
	Delta		
P	Panasonic		

Home sensor	
Out side	
C	Motor side
D	Opposite motor side
No sensor	
E	None

Limit sensor	
Out side	
3	1 Pc
4	2 Pcs
No sensor	
5	None

*1. Motor not included. Please refer to the "Motor Selection Table" on page 4-122 for details.

*2. When the stroke is 50mm, the sensor installation has the following restrictions.
1. Home sensor and limit sensor has to be installed on the different side of body.
2. Install sensor trigger on both side.

Allowable overhang

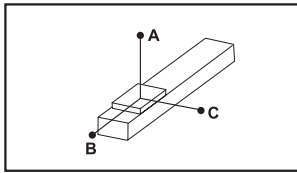

Unit: mm

Horizontal installation		A	B	C
Lead 5	20kg	1560	153	237
	35kg	890	81	126
	50kg	550	53	82
Lead 10	10kg	1730	286	412
	20kg	839	136	196
	30kg	541	86	124
Lead 20	6kg	1213	403	493
	9kg	800	264	323
	18kg	592	194	238

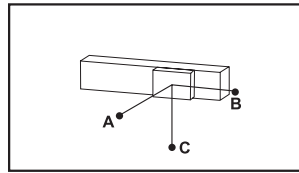

Unit: mm

Wall installation		A	B	C
Lead 5	20kg	214	153	1435
	35kg	113	81	845
	50kg	74	53	506
Lead 10	10kg	370	286	1400
	20kg	176	136	800
	30kg	112	86	495
Lead 20	6kg	444	403	760
	9kg	292	264	277
	18kg	214	194	544

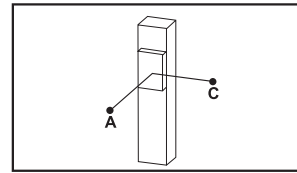

Unit: mm

Vertical installation		A	C
Lead 5	10kg	331	331
	15kg	220	220
	–	–	–
Lead 10	5kg	589	589
	8kg	368	368
	–	–	–
Lead 20	3kg	935	935
	–	–	–
	–	–	–

Static loading moment

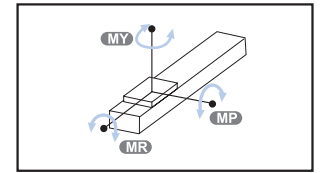

Unit: N.m

MY	318
MP	318
MR	626

- The torque value in the chart indicate the center of gravity.
- Operation life is 10000km when the product is using under the specified conditions.
- Data information is not for ceiling-mount inverse use.
Contact us for the details if you want to apply ceiling-mount inverse usage.

METG-8 Dimensions

SLIDER ELECTRIC CYLINDER – BUILT-IN GUIDEWAY (WITHOUT MOTOR)



BC

Motor direct connection

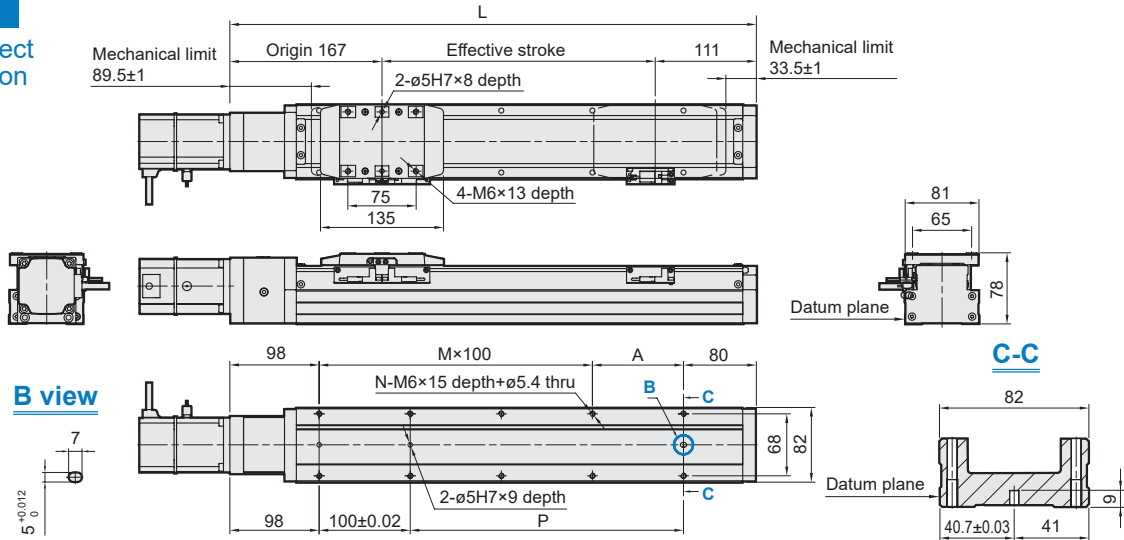

Unit: mm

Stroke	50	100	150	200	250	300	350	400	450	500	550	600	650	700	750	800	850	900	950	1000	1050	1100
L	328	378	428	478	528	578	628	678	728	778	828	878	928	978	1028	1078	1128	1178	1228	1278	1328	1378
A	50	100	50	100	50	100	50	100	50	100	50	100	50	100	50	100	50	100	50	100	50	100
M	1	1	2	2	3	3	4	4	5	5	6	6	7	7	8	8	9	9	10	10	11	11
N	6	6	8	8	10	10	12	12	14	14	16	16	18	18	20	20	22	22	24	24	26	26
P	50	100	150	200	250	300	350	400	450	500	550	600	650	700	750	800	850	900	950	1000	1050	1100
KG	5.18	5.54	5.91	6.27	6.64	7	7.37	7.73	8.1	8.46	8.83	9.19	9.56	9.92	10.29	10.65	11.02	11.38	11.75	12.11	12.48	12.85

BM

Motor on lower side

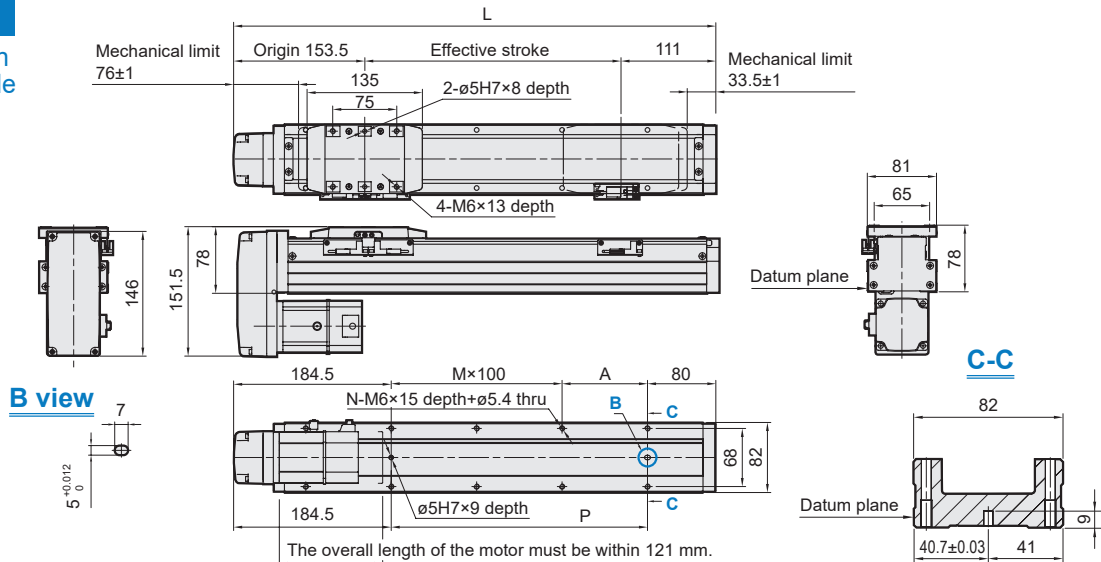

Unit: mm

Stroke	50	100	150	200	250	300	350	400	450	500	550	600	650	700	750	800	850	900	950	1000	1050	1100
L	314.5	364.5	414.5	464.5	514.5	564.5	614.5	664.5	714.5	764.5	814.5	864.5	914.5	964.5	1014.5	1064.5	1114.5	1164.5	1214.5	1264.5	1314.5	1364.5
A	50	100	50	100	50	100	50	100	50	100	50	100	50	100	50	100	50	100	50	100	50	100
M	0	0	1	1	2	2	3	3	4	4	5	5	6	6	7	7	8	8	9	9	10	10
N	4	4	6	6	8	8	10	10	12	12	14	14	16	16	18	18	20	20	22	22	24	24
P	50	100	150	200	250	300	350	400	450	500	550	600	650	700	750	800	850	900	950	1000	1050	1100
KG	5.19	5.6	6.12	6.64	7.16	7.68	8.2	8.72	9.24	9.76	10.28	10.8	11.32	11.84	12.36	12.88	13.4	13.92	14.44	14.96	15.48	16

* When motor with brake assembled on down side, or the total length over than spec limit, it may not use standard pinhole. Please contact us if you need more information and requirement.

METG-8 Dimensions



SLIDER ELECTRIC CYLINDER – BUILT-IN GUIDEWAY (WITHOUT MOTOR)

mindman

BL

Motor on left side

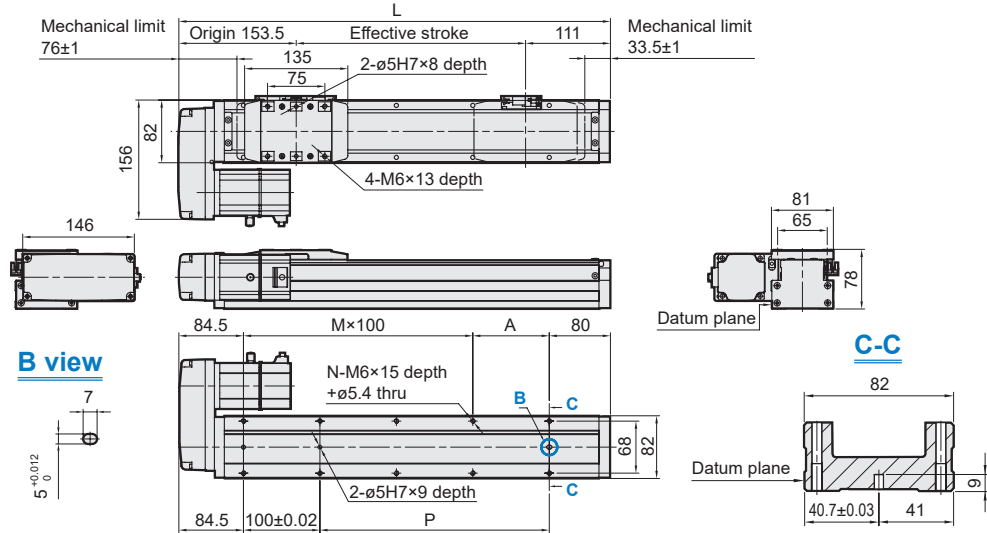

Unit: mm

Stroke	50	100	150	200	250	300	350	400	450	500	550	600	650	700	750	800	850	900	950	1000	1050	1100
L	314.5	364.5	414.5	464.5	514.5	564.5	614.5	664.5	714.5	764.5	814.5	864.5	914.5	964.5	1014.5	1064.5	1114.5	1164.5	1214.5	1264.5	1314.5	1364.5
A	50	100	50	100	50	100	50	100	50	100	50	100	50	100	50	100	50	100	50	100	50	100
M	1	1	2	2	3	3	4	4	5	5	6	6	7	7	8	8	9	9	10	10	11	11
N	6	6	8	8	10	10	12	12	14	14	16	16	18	18	20	20	22	22	24	24	26	26
P	50	100	150	200	250	300	350	400	450	500	550	600	650	700	750	800	850	900	950	1000	1050	1100
KG	5.19	5.6	6.12	6.64	7.16	7.68	8.2	8.72	9.24	9.76	10.28	10.8	11.32	11.84	12.36	12.88	13.4	13.92	14.44	14.96	15.48	16

BR

Motor on right side

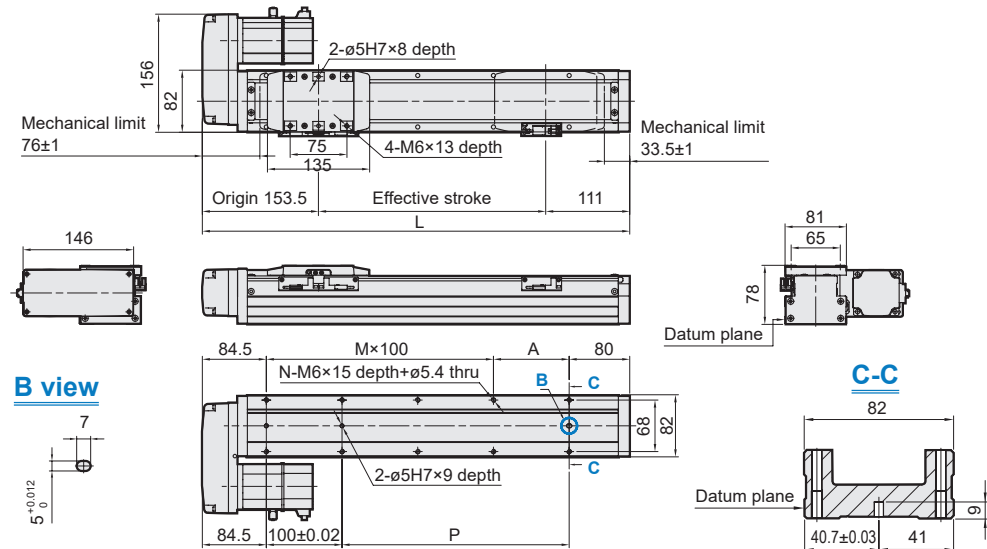

Unit: mm

Stroke	50	100	150	200	250	300	350	400	450	500	550	600	650	700	750	800	850	900	950	1000	1050	1100
L	314.5	364.5	414.5	464.5	514.5	564.5	614.5	664.5	714.5	764.5	814.5	864.5	914.5	964.5	1014.5	1064.5	1114.5	1164.5	1214.5	1264.5	1314.5	1364.5
A	50	100	50	100	50	100	50	100	50	100	50	100	50	100	50	100	50	100	50	100	50	100
M	1	1	2	2	3	3	4	4	5	5	6	6	7	7	8	8	9	9	10	10	11	11
N	6	6	8	8	10	10	12	12	14	14	16	16	18	18	20	20	22	22	24	24	26	26
P	50	100	150	200	250	300	350	400	450	500	550	600	650	700	750	800	850	900	950	1000	1050	1100
KG	5.19	5.6	6.12	6.64	7.16	7.68	8.2	8.72	9.24	9.76	10.28	10.8	11.32	11.84	12.36	12.88	13.4	13.92	14.44	14.96	15.48	16